

## Operating and Installation Instructions

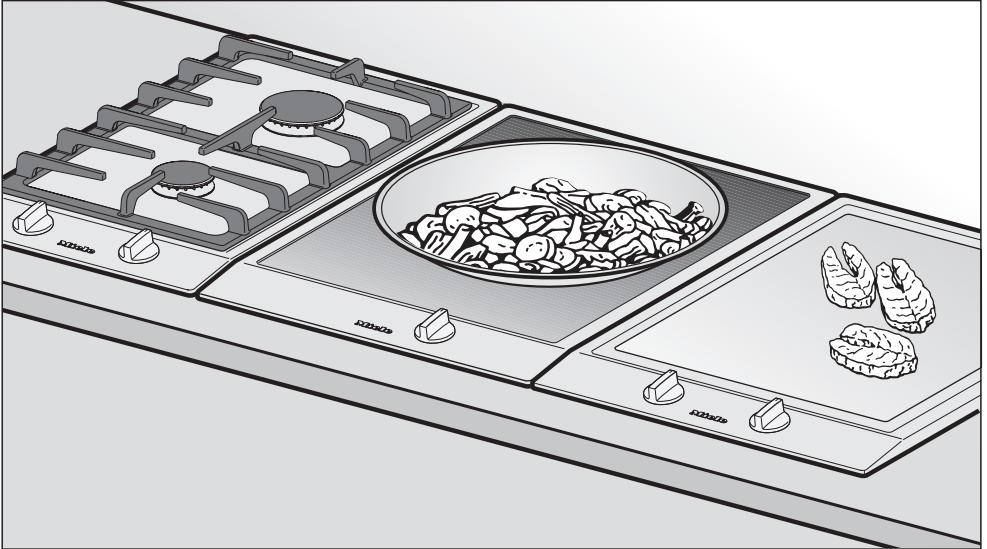

## Electric Barbecue CS 1322

To prevent accidents and  
machine damage,  
read the Operating Manual  
**before**  
installation or use.

en - CA

M.-Nr. 07 374 400

# Contents

---

<b>IMPORTANT SAFETY INSTRUCTIONS</b> . . . . .	3
<b>Description of the unit</b> . . . . .	7
<b>Before using for the first time</b> . . . . .	8
<b>Use</b> . . . . .	9
Prepare the appliance . . . . .	9
Turning On/Off . . . . .	9
Grilling . . . . .	10
After grilling . . . . .	10
Grilling times . . . . .	11
<b>Safety Feature</b> . . . . .	12
Overheat protection . . . . .	12
Safety cut-out feature . . . . .	12
<b>Cleaning and care</b> . . . . .	13
<b>Frequently asked questions</b> . . . . .	15
<b>Technical Service</b> . . . . .	16
<b>Additional Accessories</b> . . . . .	17
<b>SAFETY INSTRUCTIONS FOR INSTALLATION</b> . . . . .	20
<b>Installation</b> . . . . .	23
Installation dimensions . . . . .	24
Cut out . . . . .	25
Installation of multiple appliances . . . . .	26
Attach the spring clips and support bars . . . . .	29
Installing the appliance . . . . .	31
Sealing . . . . .	32
Tiled surfaces . . . . .	32
<b>Electrical connection</b> . . . . .	33
<b>Help protect our environment</b> . . . . .	34

# IMPORTANT SAFETY INSTRUCTIONS

**WARNING- When using your appliance follow basic precautions, including the following:**

**Read all instructions before installation or use to prevent injury and appliance damage.**

**This appliance conforms to all uniform safety codes and regulations. The manufacturer cannot be held responsible for damage or injury caused by improper use of this appliance.**

**Keep these operating instructions in a safe place and pass them on to any future user.**

**SAVE THESE INSTRUCTIONS**

## Children

▶ Children should not be left unattended in an area where the appliance is in use. Never allow children to sit or stand on any part of the appliance.

**Caution:** Do not store items of interest to children in cabinets above the appliance. Children climbing on the appliance to reach these items could be injured.

▶ The appliance is hot during use and remains so for some time after being switched off. Keep children away from the appliance.

▶ Ensure that any packing material, is disposed of safely and kept out of the reach of children. Danger of suffocation!

▶ Be sure that children cannot access the drain valve on the appliance, potentially releasing hot water.

## Correct usage

▶ Only use this appliance for residential cooking, and for the purposes described in this manual. Other uses are not permitted and can be dangerous. The manufacturer will not be held liable for damage caused by unauthorized use or improper operation of any kind.

▶ Persons who lack physical, sensory or mental abilities, or experience with the appliance should not use it without supervision or instruction by a responsible person.

# IMPORTANT SAFETY INSTRUCTIONS

---

## Technical Safety

▶ Installation, repair and maintenance work should be performed by a Miele authorized service technician. Work by unqualified persons could be dangerous and may void the warranty.

▶ Before installing the appliance, check for externally visible damage. **Do not** operate a damaged appliance.

▶ To guarantee the electrical safety of this appliance, continuity must exist between the appliance and an effective grounding system. It is imperative that this basic safety requirement be met. If there is any doubt, have the electrical system of the house checked by a qualified electrician. The manufacturer will not be held responsible for damages caused by the lack, or inadequacy, of an effective grounding system.

▶ Before installation, make sure that the voltage and frequency listed on the data plate correspond with the household electrical supply. This data must correspond to prevent injury and appliance damage. Consult a qualified electrician if in doubt.

▶ Do not use an extension cord to connect this appliance to electricity. Extension cords do not guarantee the required safety of the appliance.

▶ Do not use the appliance until it has been properly installed in the countertop.

▶ Before servicing, disconnect the appliance from the main power supply.

▶ Do not operate any appliance with a damaged cord or plug, or if the appliance has been damaged in any manner. Contact Miele's Technical Service Department.

▶ Under no circumstances open the outer casing of the appliance.

▶ While the appliance is under warranty repairs should only be performed by an authorized service technician. Otherwise the warranty is void.

▶ In the event of any damage to the appliance, it must be turned off immediately and disconnected from the main power supply. Contact Miele's Technical Service Department. Do not use the appliance until it has been repaired. Ensure power is not supplied to the appliance until repair work is completed.

▶ Defective components should be replaced by Miele original spare parts only. Only with these parts can the manufacturer guarantee the safety of the appliance.

# IMPORTANT SAFETY INSTRUCTIONS

## Safety

- ▶ The appliance is hot during use and remains so for some time after being switched off. Be careful not to touch the appliance if it may still be hot.
- ▶ Protect your hands with oven mitts or potholders when using the appliance. Use only dry, heat resistant potholders. Moist or damp potholders used on hot surfaces can result in steam burns. Do not let the potholder touch the hot heating elements. Do not use towels or other bulky items near the appliance.
- ▶ Do not heat unopened containers. Built-up pressure may cause the container to burst and result in injury.
- ▶ Never use the appliance to heat a room. Due to the high temperatures radiated, objects left near the appliance could catch fire.
- ▶ Do not store items on the appliance when not in use. Items could melt or catch fire from residual heat or if the appliance is turned on inadvertently.
- ▶ Never cover the appliance with a cloth. A fire may result.
- ▶ Be aware of loose fitting or hanging garments when operating the appliance, they may present a fire hazard.
- ▶ Never leave an appliance unattended at high settings or when cooking with oil or fat. Overheated oil could ignite. Always heat oil slowly, monitoring it as it heats.
- ▶ Do not use water on grease fires. Smother or use a dry chemical or foam-type extinguisher on any fire or flame.
- ▶ Do not use aluminum dishes, pans, pots or foil on the grill. Never cover the grill grate with aluminum foil. Aluminum will cause overheating and may damage the grill grate.
- ▶ Clean the lava rocks on a regular basis and change them when needed. Fat-saturated stones can easily catch fire.
- ▶ The water trough must always be filled with water when the appliance is being used.
- ▶ Make certain that the power cords of small appliances do not come in contact with the appliance. The insulation of the cable could become damaged. Danger of electric shock!

# IMPORTANT SAFETY INSTRUCTIONS

---

- ▶ To prevent burns and breathing difficulty, allow the appliance to cool before cleaning. Some cleaners may produce toxic fumes if applied to a hot surface.
- ▶ When wiping spills on a hot appliance with a wet sponge or cloth, be careful to avoid steam burns.
- ▶ Do not let flammable materials, i.e. cooking grease, accumulate on the appliance.
- ▶ Do not use a steam cleaner to clean this appliance. Steam could penetrate electrical components and cause a short circuit.

The manufacturer cannot be held liable for damage caused by non-compliance with these Important Safety instructions.

**SAVE THESE INSTRUCTIONS  
AND REVIEW THEM  
PERIODICALLY**

# Description of the unit

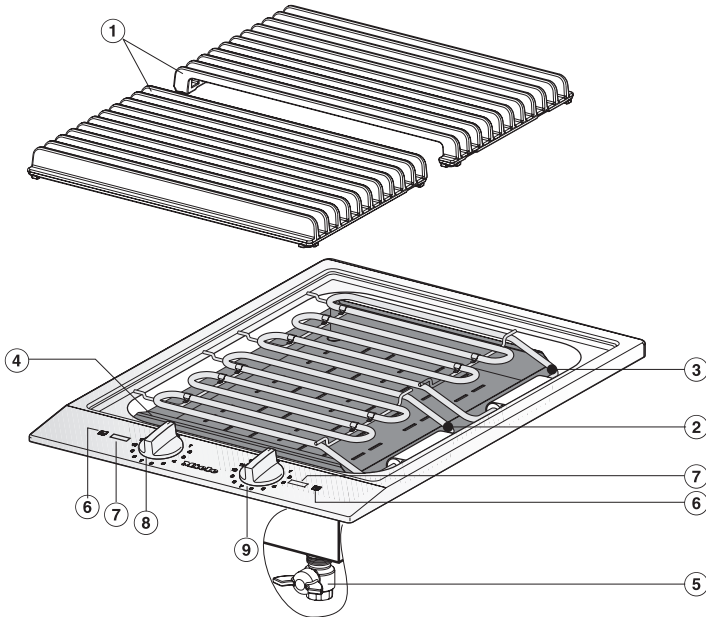

- ① Grates
- ② Heating element, front
- ③ Heating element, rear
- ④ Lava rock container
- ⑤ Drain valve
- ⑥ Cooking area indicators
- ⑦ Display

Control knobs:

- ⑧ front
- ⑨ rear

## Display



⑩

⑩ On/Off indicator

## Before using for the first time

---

### Clean the appliance

- Clean the water trough and the grill with a mild solution of warm water and liquid dish liquid, then dry with a soft cloth (see "Cleaning and care").
- Wipe the other surfaces down with a damp cloth and dry.

### Heat the appliance

Metal components of the appliance have a protective coating which may give off a slight odor the first time the appliance is heated.

The smell will dissipate after a short time and does not indicate a faulty connection or appliance defect.



## Prepare the appliance

You can use the electric barbecue with or without the lava rocks.

Without the lava rocks: food will stay more moist, from the rising steam.

With the lava rocks: the food will have a more pronounced grilled aroma and flavor.

- Check that the drain valve is closed.
- Remove the grate, raise the heating element, and remove the lava rock container (if desired).

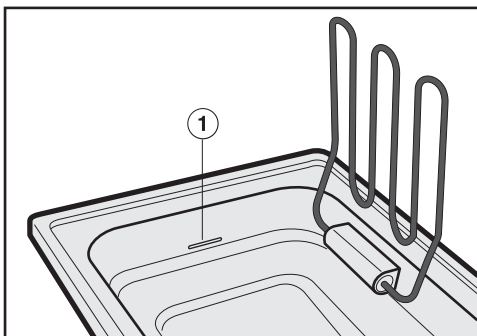

- If grilling **without lava rocks** fill the water trough with water up to mark ①, with approx. 4.0 liters of water.

If grilling **with lava rocks**, fill the water trough with approx. 1.8 liters of water.

- Return the filled lava rock container to the water trough (if desired).
- The heating element can now be turned down.
- Replace the grates.

## Turning On/Off

 Do not leave the appliance unattended while in use.

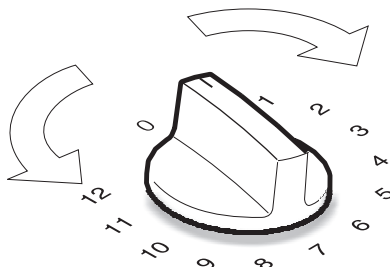

The electric barbecue is divided into two heating areas, which can be used and adjusted separately. For large quantities, you can use the entire surface for cooking. For smaller quantities, you can, for example, cook in the front and keep food warm at the back, using a lower setting.

The heating elements can be switched on and off by turning the appropriate knob left or right.

When the appliance is switched on, the On/Off indicator ■ comes on. It goes out when it is switched off.

# Use

---

## Grilling

While grilling, watch the level of water in the trough. If necessary, add more water.

Do not use aluminum dishes, pans, pots or foil on the grill. Never cover the grill grate with aluminum foil. Aluminum will cause overheating and may damage the grill grate.

- Turn one or both operating knobs to power level "12".  
Pre-heat the grill with both racks in place for approx. 10 minutes.

Make sure the operating knob(s) are set precisely to power level 12. If the knobs are not set to the exact position, the heating will not work with maximum power.

- Set the power level.
- Grill food as desired.

## Tips

- To minimize splattering, dry moist foods with paper towels before grilling.
- Marinate food before grilling, to enhance the flavors.
- To prevent sticking non-marinated items should be brushed lightly with oil before grilling. Only use oils that can tolerate high temperatures.
- You can shorten the grilling time for potatoes in foil and corn on the cob, by pre-cooking the potatoes for approx. 15 - 40 minutes (depending on the size) and the corn for approx. 10 - 15 minutes.

## After grilling

- Turn the appliance off.
- After each use, clean the appliance while it is still somewhat warm to the touch (see "Cleaning and care").
- After grilling with the lava rocks check the condition of the rocks. If they are dark in color, they are saturated with fat and need to be cleaned or replaced. See "Cleaning and Care - Lava rocks".

**Grilling times**

<b>Food item</b>	<b>Grilling time in minutes</b>
<b>Meat and sausage</b>	
Boneless steak	8 - 10
Chicken breasts	16 - 18
Cutlets	8 - 12
Filet steak	4 - 10
Hamburgers	12 - 16
Kebabs	14 - 18
Lamb chop	4 - 8
Sausages	6 - 8
Spare Ribs	15 - 20
T-Bone Steak	10 - 20
Turkey cutlet	8 - 10
<b>Fish / seafood</b>	
Salmon steak	10 - 12
Shrimp	2 - 4
Trout	12 - 16
Tuna steak	6 - 8

<b>Food item</b>	<b>Grilling time in minutes</b>
<b>Vegetables</b>	
Corn (parboiled)	5 - 8
Eggplant	6 - 8
Potatoes in foil (parboiled)	10 - 20
Tomato halves	2 - 4
Onions	14 - 16
Pepper strips	2 - 3
Vegetable kebabs	5 - 6
<b>Fruit</b>	
Apple slices	2 - 3
Peach halves	2 - 3
Pineapple slices	2 - 3
<b>Other</b>	
Toast/bread	2 - 3
Tofu	4 - 6

The times shown in the table serve as guide only and apply for grilling at power level 9 -12 on a pre-heated grill. The grilling time depends on the type, preparation, and thickness of the food item.

# Safety Feature

---

## Overheat protection

If there is not enough water in the water trough, the overheat protection automatically switches the appliance off.

- Pour in cold water.

Once the appliance has cooled down and the heating element switches back on, you can continue grilling as normal.

## Safety cut-out feature

The safety cut-off ensures that the heating element will only work if it is lowered.

 Under no circumstances use a steam cleaner to clean this appliance. Pressurized steam could cause permanent damage to the surface and to components for which the manufacturer cannot accept responsibility.

Never use strong cleaners e.g. oven sprays, stain or rust removers. Scouring pads and abrasive cleaning agents should only be used on the heating element.

Do not use any sharp pointed objects which could damage the seal between the ceramic surface and the surrounding frame, and between the frame and the countertop.

When using cleaning agents for stainless steel always follow the manufacturer's instructions on the packaging.

After cleaning use a soft, dry cloth to remove any moisture. This way you will prevent the build up of limescale deposits.

### Stainless steel

Clean stainless steel surfaces with warm water and liquid dish soap applied with a non-abrasive sponge and then wipe dry with a soft cloth. Soak baked or hardened spills first to loosen them.

Stainless steel surfaces can be cleaned using a non-abrasive stainless steel cleaner.

To help prevent resoiling, a conditioner for stainless steel can also be used. Apply sparingly with even pressure.

Do not use stainless steel cleaner on or around the **printing**, it may rub off. Use only a soft sponge with some dish liquid and warm water to clean this area.

### Grates and lava rock container

After each use, clean the grates and lava rock container with warm water and liquid dish soap. Pre-soak any heavy soiling, then remove with a brush. Dry thoroughly.

**Do not** use stainless steel conditioner on the lava rock container.

### Heating element

Grill residue can best be removed from the heating element using a scouring pad.

# Cleaning and care

## Lava rocks

Clean the lava rocks on a regular basis.

To do so, put the rocks in a container with mild solution of warm water and liquid dish soap. Let them soak briefly, stirring occasionally. Drain water and rinse rocks. Repeat this process 2 to 3 times with fresh water. Lay the rocks on a large kitchen towel to dry.

Clean the pumice stones to remove the used layer. The stones will wear down depending on how often they are used.

Once the volume in the pumice stone container has fallen by half, it will need to be re-filled.

## Water trough

- Let the water cool to a safe temperature to prevent burns.
- Place a container (large enough to hold all water in the trough) under the drain valve.

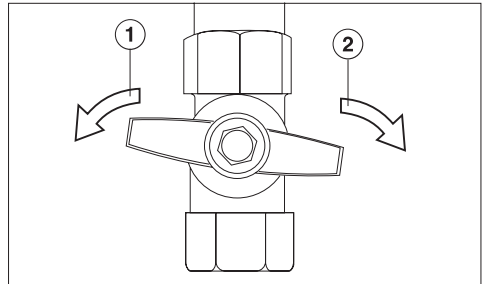

- Slowly open the drain valve by turning it **counterclockwise**, ①.
- Once the water has drained, close the drain valve by turning it **clockwise**, ② until the water flow stops.
- Fill the water trough with a mild solution of liquid dish soap and warm water, and rinse it out thoroughly. Use a bottle brush to clean the drain.
- Allow the solution to drain.
- Rinse with warm water and dry.

**Do not** use stainless steel conditioner on the water trough.

Make sure that the underside of the appliance is always accessible for draining away the water. Remember to let the water cool before draining to prevent burns.

## Frequently asked questions

 Repairs should only be carried out by an authorized technician in accordance with local and national safety regulations. Unauthorized repairs could cause injury or appliance damage. The manufacturer cannot be held responsible for unauthorized work.

### What if the appliance does not heat up after it is turned on?

Possible fault	Solution
The overheat protection was triggered.	See "Overheat protection"
The fuse or breaker was tripped.	Contact a qualified electrician or Miele Technical Service for assistance.

### What if the food does not get brown, even though the appliance was pre-heated for 10 minutes at level 12?

The knob is not exactly set to level 12, and the appliance is not operating at full power.	Correct the setting.
--	----------------------

## Technical Service

---

In the event of a fault which you cannot easily fix yourself, please contact the Miele Technical Service Department at the address on the back of this booklet.

When contacting Technical Service please quote the serial number and model of the appliance. This information is visible on the silver data plate supplied with the appliance.



## Additional Accessories

---

Miele offers a variety of additional accessories for its appliances. All accessories can be ordered from Miele.

### Griddle CSGP 1400

Cast grill plate, with one smooth side and one ridged side, for CS 1322

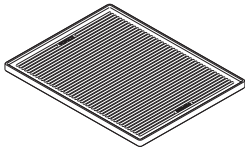

### Wire rack for Griddle Plate CSGP1400

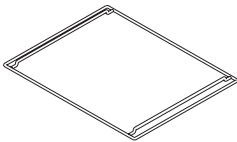

### Handle

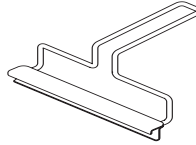

### Stainless steel and ceramic surface cleaners

Help to remove soiling, lime spots, mild staining, fingerprints, etc. while maintaining the appearance of the appliance between cleanings.

### Lava rocks

Lava rocks come standard with the electric barbecue, they can also be reordered as necessary.



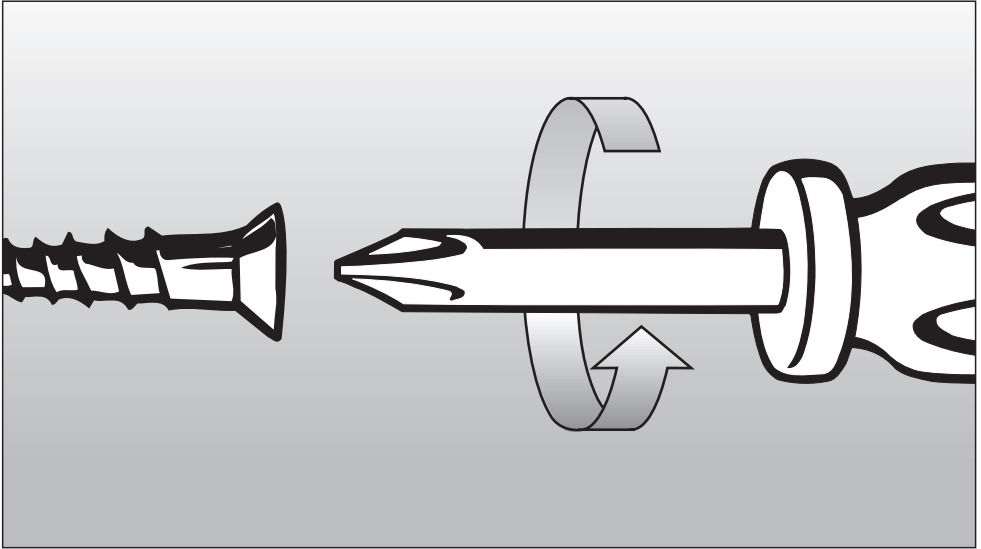

## Installation Instructions

IMPORTANT: SAVE FOR THE LOCAL ELECTRICAL INSPECTOR'S USE

To prevent accidents  
and machine damage  
read these instructions  
**before**  
installation or use.

# SAFETY INSTRUCTIONS FOR INSTALLATION

## Note to the installer:

**Please leave this instruction book with the consumer for the local electrical inspector's use.**

The minimum distances given in these Installation Instructions must be observed in order to ensure safe operation. Failure to do so increases the risk of fire.

The cabinetry and venting hood should be installed first to prevent damage to the appliance.

- ▶ The countertop must be bonded with heat resistant (212 °F/100 °C) adhesive to prevent distortion or dissolving. The wall strips must be heat-resistant as well.
- ▶ To eliminate the risk of burns or fire by reaching over heated surfaces cabinet storage space above the appliance should be avoided. If cabinet storage is necessary, the risk can be reduced by installing a venting hood to project horizontally a minimum of 5" (127 mm) beyond the bottom of the cabinets.
- ▶ This appliance has not been designed for maritime use or for use in mobile installations such as recreational vehicles or aircraft. However, under certain conditions it may be possible for installation in these applications. Please contact the Miele Technical Service Department with specific requirements.

- ▶ The grill must not be installed directly next to the CS 1421 (Salamander). It is essential to maintain a distance of at least 5 <sup>7</sup>/<sub>8</sub>" (150 mm) between these two appliances.
- ▶ You must ensure the power cable for the appliance will not come under any mechanical strain once installed e.g., while the water is draining.
- ▶ Be sure that after installation the power cord does not come into contact with any parts of the appliance which may become hot.
- ▶ The appliance must not be permanently sealed into the countertop when installed. The sealing strip under the edge of the appliance provides a sufficient seal for the countertop. See "Sealing".

**Keep this instruction book in a safe place for reference and pass it on to any future user.**

# SAFETY INSTRUCTIONS FOR INSTALLATION

## Safety distances above the appliance

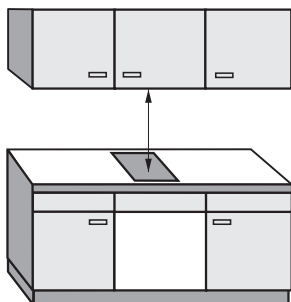

The minimum safety distance given by the hood manufacturer must be maintained between the grill and the hood above it. See the installation instructions of the hood for these safety measurements.

If the hood manufacturers instructions are not available or if flammable objects are installed over the grill (e.g. cabinets, utensil rail, etc.), a minimum safety distance of 30" (760 mm) must be maintained.

If there is more than one appliance beneath a hood (e.g. wok burner and electric grill), and they have different minimum safety distances always observe the greater distance.

# SAFETY INSTRUCTIONS FOR INSTALLATION

## Safety distances to the sides of the appliance

The appliance should only be installed as shown in the illustrations while maintaining the required safety distances shown. Do not install the appliance between two tall cabinets, this is a fire hazard.

A distance of at least 2" (50 mm) must be kept between the countertop cut-out and the rear wall because of the high temperatures radiated.

The minimum distance ① between the worktop cut-out and a wall or tall unit to the right or left of it is:

**2" (50 mm)** for CS 1112  
CS 1122  
CS 1212  
CS 1221  
CS 1223  
CS 1326  
CS 1411

**6" (150 mm)** for CS 1312  
CS 1322  
CS 1421

**10" (250 mm)** for CS 1011  
CS 1012  
CS 1028

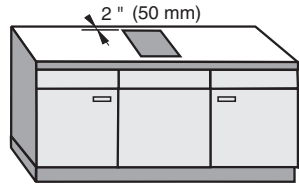
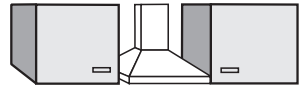

**recommended**

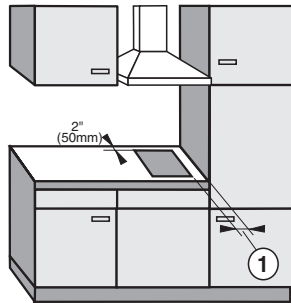

**not recommended**

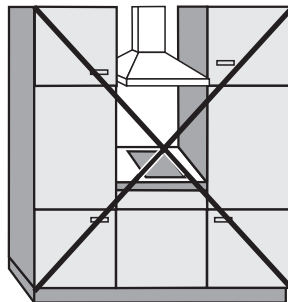

**not permitted**

## Safety distance when installing the appliance near a wall with trim or a back splash

A minimum distance of 2" (50 mm) between the trim or back splash and the countertop cut-out if required.

This distance is only necessary if these items are made of combustible materials e.g. wood. If the trim or back splash is made of a non-combustible material, the required safety distance can be reduced by the thickness of the wall covering material.

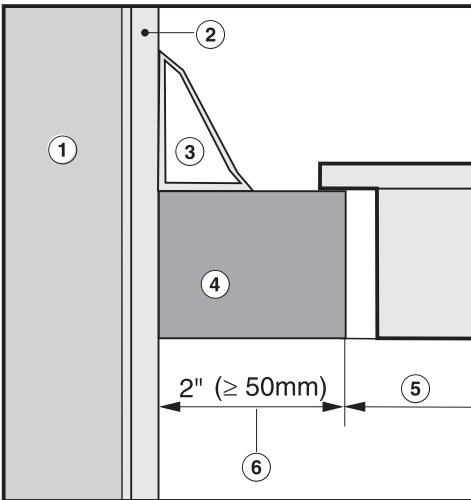

- ① Wall frame
- ② Sheet rock or wall board
- ③ Trim or back splash
- ④ Countertop
- ⑤ Countertop cut-out
- ⑥ 2" (50 mm) minimum clearance

# Installation

## Installation dimensions

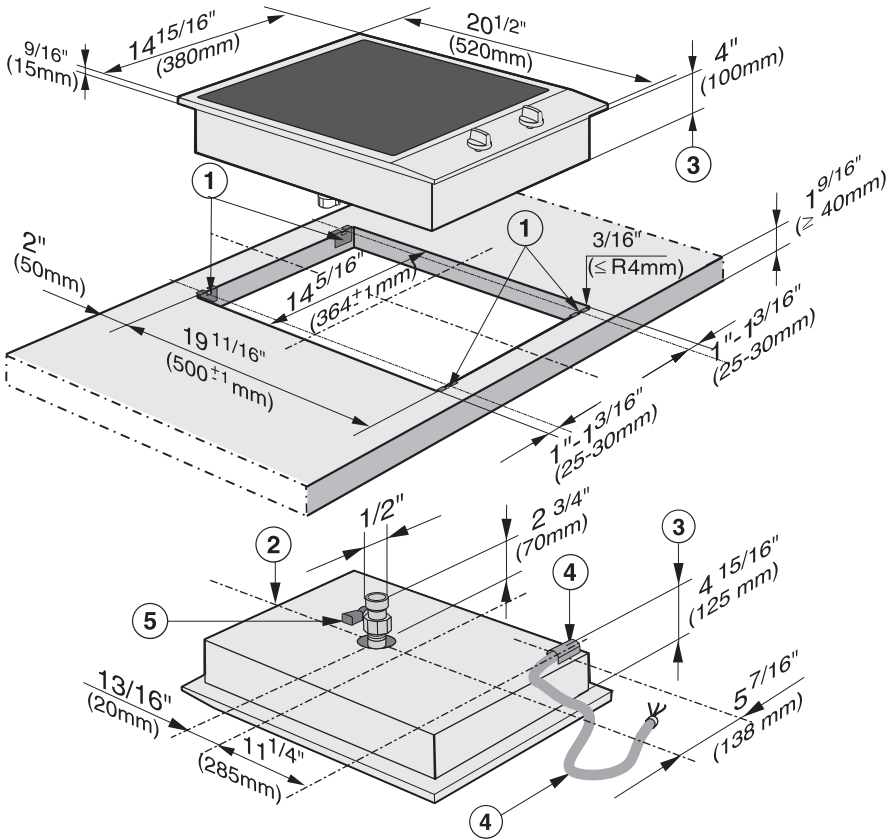

- ① Spring clips
- ② Appliance front
- ③ Installation height
- ④ Power supply box with connection cable, L =  $78\frac{3}{4}"$  (2000 mm)
- ⑤ Drain valve



## Cut out

- Make the worktop cut-out for one or more appliances as applicable. Remember to maintain a **minimum safety distance** from the **back wall**, as well as from any **tall unit or side wall** to the right or left of the appliance(s). See also "SAFETY INSTRUCTIONS FOR INSTALLATION".
- Seal the cut surfaces with a suitable sealant to avoid swelling caused by moisture. The materials used must be heat resistant.

If during installation the seal around the frame does not sit flush with the countertop in the corners, the corner radius, maximum  $\frac{3}{16}$ " (4 mm), can be carefully filed down to fit.

# Installation

## Installation of multiple appliances

When installing more than one combiset appliance, a support bar ② must be installed between the appliances.

### Countertop cut-out two appliances

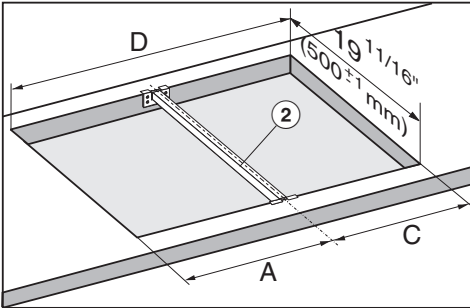

For the installation of **two appliances** the width of the countertop cut-out D is the sum of A and C.

**A, B and C** = appliance widths  
 $11 \frac{5}{16}$ " , 15" or  $22 \frac{11}{16}$ "  
(288 mm, 380 mm or 576 mm)  
**minus  $\frac{5}{16}$ " (8 mm)** to allow for the overhang

**D** = width of the countertop cut-out

### Countertop cut-out three appliances

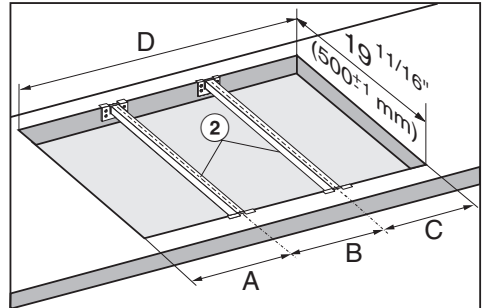

For the installation of **three appliances** the width of the countertop cut-out D is the sum of A and B and C.

If **more than three appliances** are being installed, you will need to add, A, B or C for each additional appliance.

## Sample calculations for a countertop cut-out for three appliances

<b>A</b> appliance width minus $\frac{5}{16}$ " (8 mm)	<b>B</b> appliance width	<b>C</b> appliance width minus $\frac{5}{16}$ " (8 mm)	<b>D</b> <b>Countertop cut-out</b>
11" (280 mm)	$11 \frac{5}{16}$ " (288 mm)	11" (280 mm)	$33 \frac{3}{8}$ " (848 mm)
11" (280 mm)	15" (380 mm)	$14 \frac{5}{8}$ " (372 mm)	$40 \frac{5}{8}$ " (1032 mm)
11" (280 mm)	$22 \frac{11}{16}$ " (576 mm)	$22 \frac{3}{8}$ " (568 mm)	$56 \frac{1}{16}$ " (1424 mm)
$14 \frac{5}{8}$ " (372 mm)	$11 \frac{5}{16}$ " (288 mm)	11" (280 mm)	37" (940 mm)
$14 \frac{5}{8}$ " (372 mm)	15" (380 mm)	$14 \frac{5}{8}$ " (372 mm)	$44 \frac{1}{4}$ " (1124 mm)
$14 \frac{5}{8}$ " (372 mm)	$22 \frac{11}{16}$ " (576 mm)	$22 \frac{3}{8}$ " (568 mm)	$59 \frac{11}{16}$ " (1516 mm)
$22 \frac{3}{8}$ " (568 mm)	$11 \frac{5}{16}$ " (288 mm)	11" (280 mm)	$44 \frac{3}{4}$ " (1136 mm)
$22 \frac{3}{8}$ " (568 mm)	15" (380 mm)	$14 \frac{5}{8}$ " (372 mm)	52" (1320 mm)
$22 \frac{3}{8}$ " (568 mm)	-	$22 \frac{3}{8}$ " (568 mm)	$44 \frac{3}{4}$ " (1136 mm)

# Installation

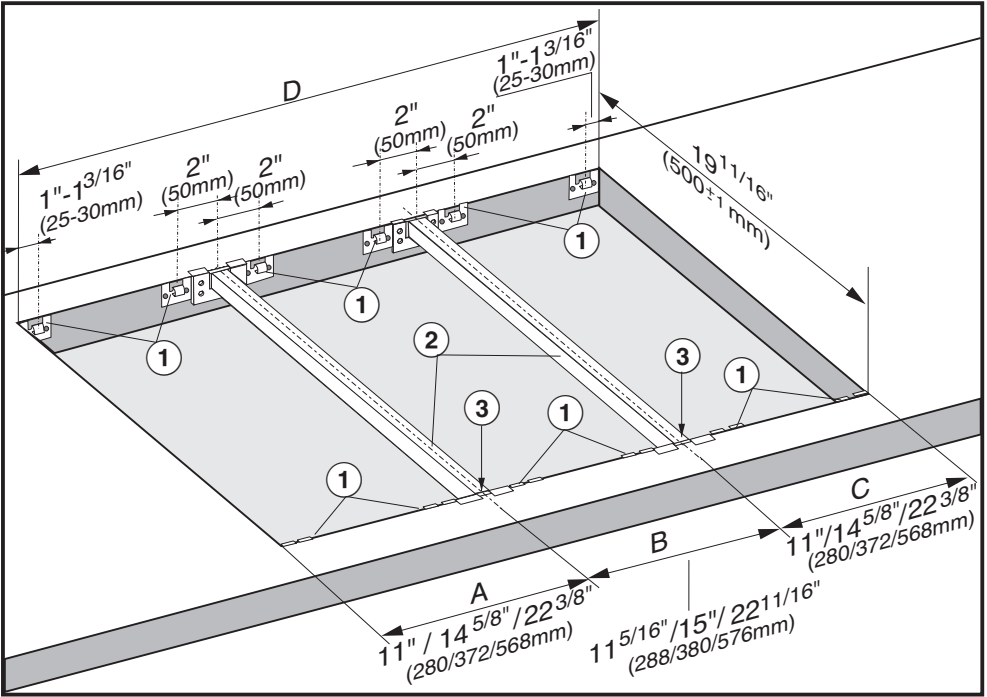

- ① Spring clips
- ② Support bars
- ③ Space between support bar and countertop

An additional support bar is required for each additional appliance. The position for attachment of an additional spacing strip depends on the width of the appliance **B**.

## Attach the spring clips and support bars

### Wood or solid surface countertops

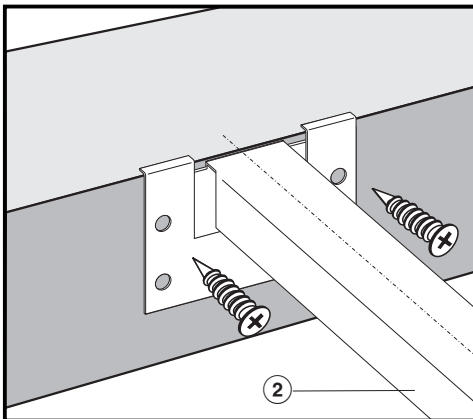
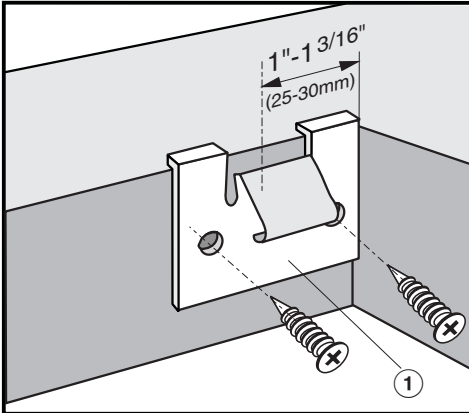

- Place the supplied spring clips ① and the support bars ② at the marked positions as shown above, by laying them on the upper edge of the cut-out and then securing them with the  $\frac{1}{8}$ " x 1" (3.5 x 25 mm) screws (supplied).

### Granite countertop

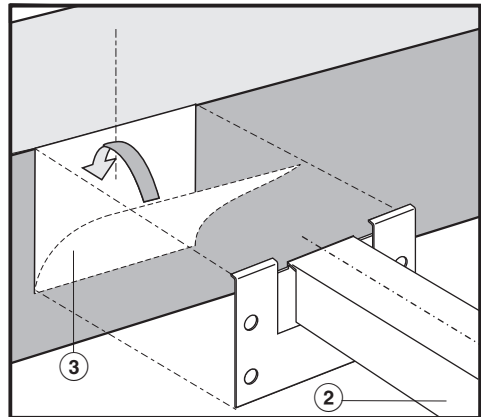
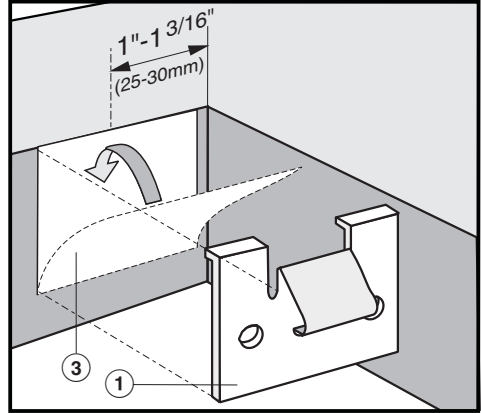

- Position and attach the spring clips ① and support bars ② with strong, double-sided tape ③.

The screws are not needed for granite countertops.

# Installation

---

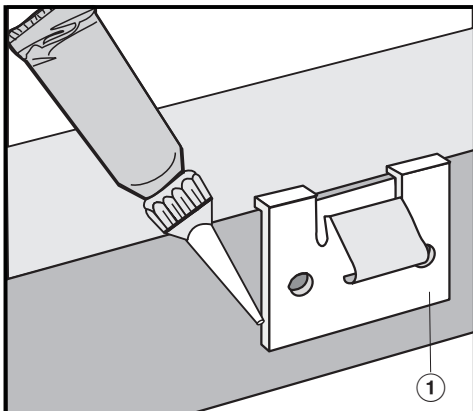

- Coat the edges of the spring clips ①,

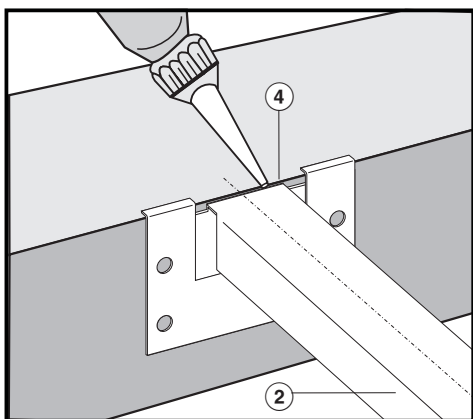

- and the space ④ between the strips ② and the countertop with silicone (supplied).

## Installing the appliance

- Feed the power cord down through the cut-out.
- Then place the front side of the appliance in the countertop cut-out.
- Then with a hand on each side of the appliance press down evenly on the edges until it clicks into position. When doing so make sure that the appliance seal sits tightly on the countertop to ensure it is sealed correctly. **Do not** permanently seal into the countertop.
- Connect the appliance to the main power supply.
- Turn the appliance on and check the function.

The appliance can be lifted out using a special tool.  
The appliance can also be pushed up and out from underneath. Note that the rear will need to be pushed out first.

# Installation

## Sealing

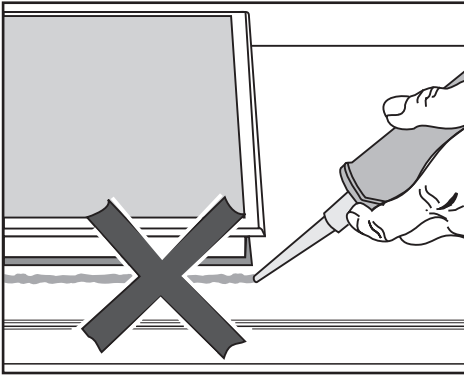

The appliance must not be permanently sealed into the countertop when installed. The sealing strip under the edge of the appliance provides a sufficient seal for the countertop.

If the appliance is sealed into position, the countertop or appliance could be damaged if it needs to be removed for maintenance or service.

## Tiled surfaces

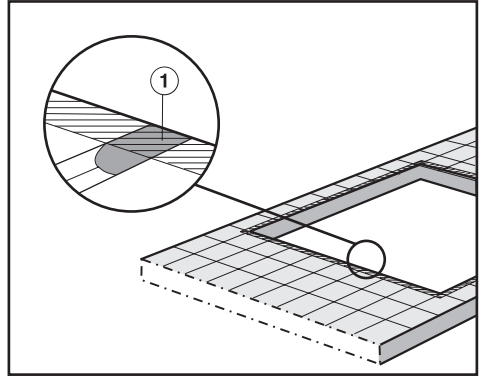

The grouting ① and shaded area under the appliance frame must be flat and even, so that the frame will lie evenly and the sealing strip under the edge of the upper part of the appliance can provide an adequate seal against the countertop.



 **CAUTION:** Before installation or servicing, disconnect the power supply by either removing the fuse, shutting off the main power supply or manually "tripping" the circuit breaker.

Installation work and repairs should only be performed by a qualified technician in accordance with all applicable codes and standards. Repairs and service by unqualified persons could be dangerous and the manufacturer will not be held responsible.

Before connecting the appliance to the power supply, make sure that the voltage and frequency listed on the data plate correspond with the household electrical supply. This data must correspond to prevent appliance damage. Consult an electrician if in doubt.

Only operate the combiset after it has been installed into the countertop.

## Power supply

- Be sure your electrical supply matches the data plate.

The combiset is equipped with a flexible metal conduit encasing 3 wires ready for connection to a grounded power supply.

A dedicated line and junction box should be used to connect the combiset to a 15 A circuit.

Black wire: connect to L1 (hot)

Red wire: connect to L2 (hot)

Green wire: connect to GND (ground)

240 V, 60 Hz, 15 A fuse rating.

Be sure the power outlet is accessible after installation.

For further information, see the wiring diagram provided with the appliance.

 **WARNING:**  
**THIS APPLIANCE MUST BE GROUNDED!**

## Installer:

**Please leave these instructions with the consumer.**

# Help protect our environment

---

## **Disposal of packing materials**

The cardboard box and packing materials are biodegradable and recyclable. Please recycle.

Ensure that any plastic wrappings, bags, etc. are disposed of safely and kept out of the reach of children.

Danger of suffocation!

## **Disposal of an old appliance**

Old appliances contain materials that can be recycled. Please contact your local recycling authority about the possibility of recycling these materials.

Before discarding an old appliance disconnect it from the electrical supply and cut off the power cord to prevent it from becoming a hazard.





## **Miele Limited**

### **Headquarters and Showroom**

161 Four Valley Drive

Vaughan, ON L4K 4V8

Phone: 800-643-5381

905-660-9936

Fax: 905-532-2290

[www.miele.ca](http://www.miele.ca)

[info@miele.ca](mailto:info@miele.ca) (general enquiries)

[professional@miele.ca](mailto:professional@miele.ca) (commercial enquiries)

### **MieleCare National Service**

Phone: 800-565-6435

905-532-2272

Fax: 905-532-2292

[customercare@miele.ca](mailto:customercare@miele.ca) (technical enquiries)